

ISL7823xEVAL1Z Evaluation Board User Guide

Description

The ISL78233EVAL1Z, ISL78234EVAL1Z, ISL78235EVAL1Z evaluation boards are used to demonstrate the performance of the ISL78233, ISL78234, ISL78235 low quiescent current, high efficiency synchronous buck regulator. The evaluation boards are intended for use by customers with requirements for Point-of-load automotive applications with 2.7V to 5.5V input supply voltage, output voltages down to 0.8V and up to 5A output current.

The ISL78233, ISL78234, ISL78235 are offered in a 3x3mm 16 Ld TQFN package with 1mm maximum height. The complete area that the regulator occupies can be as small as 0.22in².

Specifications

PART NUMBER	I _{OUT} (MAX) (A)	f _{SW} RANGE (MHz)	V _{IN} RANGE (V)	V _{OUT} RANGE (V)	PART SIZE (mm)
ISL78235	5	Programmable 1 to 4MHz	2.7 to 5.5	0.8 to 5.5	3x3
ISL78234	3				
ISL78233	4				

PCB SPECIFICATION

Board Dimension: 2.025 x 2.725 in
 # of Layers: 4
 FR-4 Thickness: 1.57mm
 Copper Weight: 2oz.

NOTES:

1. The evaluation board default V_{OUT} = 1.8V.
2. The evaluation board default f_{SW} = 2MHz.

Key Features

- 2.7V to 5.5V input voltage range
- Synchronous buck regulator up to 95% efficiency
- 1% reference accuracy over temperature
- Resistor adjustable frequency from 500kHz to 4MHz; Default set to 2MHz
- External synchronization from 1MHz to 4MHz
- 100ns maximum phase minimum on time allows wide output regulation operating at 2MHz
- Internal soft-start set to 1ms; adjustable with external soft-start capacitor
- Over-temperature, overcurrent, overvoltage and negative overcurrent protection

References

- [ISL78235 Datasheet](#)
- [ISL78233.ISL78234 Datasheet](#)

Ordering Information

PART NUMBER	DESCRIPTION
ISL78235EVAL1Z	Evaluation Board for 5A Sync Buck ISL78235
ISL78234EVAL1Z	Evaluation Board for 4A Sync Buck ISL78234
ISL78233EVAL1Z	Evaluation Board for 3A Sync Buck ISL78233



FIGURE 1. ISL78235EVAL1Z EVALUATION BOARD PHOTO

Recommended Equipment

The following equipment is recommended to perform testing:

- 0V to 5V power supply with 10A source current capability
- Electronic load capable of sinking current up to 10A
- Digital Multimeters (DMMs)
- 500MHz quad-trace oscilloscope
- Signal generator for EN and/or SYNC pins

Quick Setup Guide

1. Ensure that the circuit is correctly connected to the supply and loads prior to applying any power.
2. Connect the bias supply to V_{IN} , the plus terminal to V_{IN} (P4) and the negative return to PGND (P5).
3. Connect the output load to V_{OUT} , the plus terminal to V_{OUT} (P3) and the negative return to PGND (P7).
4. Verify that SW2 is in the proper position for PFM or PWM.
5. Verify that the position is ON for SW1.
6. Turn on the power supply and set for 2.7V to 5.0V.
7. Verify the output voltage is 1.8V for V_{OUT} .

Evaluating Other Output Voltages

The ISL78233EVAL1Z, ISL78234EVAL1Z, ISL78235EVAL1Z evaluation boards outputs are preset to 1.8V for V_{OUT} . The output voltage can be adjusted from 0.8V to 3.3V. The output voltage programming resistor, R_1 , depends on the desired output voltage of the regulator. It is recommended to have R_2 set to 100k Ω . The value for R_1 is typically between 66k Ω and 450k Ω , as shown in [Equation 1](#).

$$R_1 = R_2 \cdot (V_O / V_{FB} - 1) \quad (\text{EQ. 1})$$

For faster transient response performance, add 10pF to 22pF in parallel to R_1 . Check loop compensation analysis to insure optimum performance before use of capacitance.

Frequency Control

The ISL78233, ISL78234, ISL78235 has an FS pin that controls the frequency of operation. Programmable frequency allows for optimization between efficiency and external component size. Default switching frequency is 2MHz when FS is tied to V_{IN} ($R_{11} = 0$ and R_{12} is open). By removing R_{11} and changing the value of R_{12} , the switching frequency can be changed from 500kHz to 4MHz according to [Equation 2](#):

$$R_T [\text{k}\Omega] = \frac{220 \cdot 10^3}{f_{OSC} [\text{kHz}]} - 14 \quad (\text{EQ. 2})$$

Please refer to the [ISL78235](#), [ISL78233_234](#) datasheets for more details.

Soft-Start Control

The ISL78233, ISL78234, ISL78235 has an SS pin that controls the soft-start up time. Short SS pin to SGND for internal soft-start (approximately 1ms). Populate a capacitor CSS to adjust the

soft-start time. This capacitor, along with an internal 2.1 μ A current source sets the soft-start interval of the converter, t_{SS} .

$$C_{SS} [\mu\text{F}] = 3.5 \cdot t_{SS} [\text{s}] \quad (\text{EQ. 3})$$

C_{SS} should be more than 33nF to insure proper soft-start reset after fault condition. The ISL78233EVAL1Z, ISL78234EVAL1Z, ISL78235EVAL1Z has a default 33nF on the board for a ~10ms soft-start time.

Control Switches for EN and SYNC

The evaluation board contain switches SW1 and SW2 for control of the EN and SYNC pin. [Table 1](#) details this function.

TABLE 1. SWITCH SETTINGS

SW1	ENABLE	FUNCTION
1 (LEFT)	OFF	DISABLE IC
3 (RIGHT)	ON	ENABLE IC
SW2	SYNC	FUNCTION
1 (LEFT)	PFM	Skip mode at light load
3 (RIGHT)	PWM	Fixed PWM frequency at light load

Power Inductor

The evaluation board contains a 0.68 μ H output power inductor. It has a 13.5A saturation current that is able to handle the peak current limit of the IC. The inductor is chosen to optimize performance for $V_{IN} = 5\text{V}$, $V_{OUT} = 1.8\text{V}$ at 2MHz switching frequency for up to 5A output currents.

Internal vs External Compensation

The ISL78233, ISL78234 and ISL78235 feature an internal compensation network on the output of the error amplifier. The internal compensation simplifies design by reducing external components while stabilizing the regulator under transient load response. To use internal compensation network, tie the COMP pin to VDD.

The restriction of an internal compensation network is that it does not provide flexibility to optimize the compensation network for conditions when additional output capacitance is needed to minimize output overshoot from fast transient loading. The added capacitance affects the stability and response of the feedback loop. The internal compensation network is well suited for a wide range of switching frequencies and load di/dt transients, however if the feedback network needs to be better optimized for the application, external compensation should be used. When the COMP pin is not connected to VDD, an RC network from COMP pin to GND is used to provide the external compensation.

For more information on the specification of the internal compensation network and designing for stability, refer to [ISL78235](#), [ISL78233_234](#) datasheets for more details.

PCB Layout Recommendation

The PCB layout is a very important converter design step to make sure the designed converter works well. For ISL78233, ISL78234, ISL78235, the power loop is composed of the output inductor L_o , the output capacitor (COUT), the PHASE pins and the PGND pins. It is necessary to make the power loop as small as possible and the connecting traces among them should be direct, short and wide. The switching node of the converter (PHASE pins) and the traces connected to the node are noisy. Keep the voltage feedback trace away from these noisy traces. The input capacitor should be placed as close as possible to the VIN/VDD and GND pin. The ground of input and output capacitors should be connected as close as possible. The heat of the IC is mainly dissipated through the thermal pad. Maximizing the copper area connected to the thermal pad is preferable. In addition, a solid ground plane is helpful for better EMI performance. It is recommended to add at least 5 vias ground connection within the pad for the best thermal relief.

ISL78233EVAL1Z, ISL78234EVAL1Z, ISL78235EVAL1Z Schematic

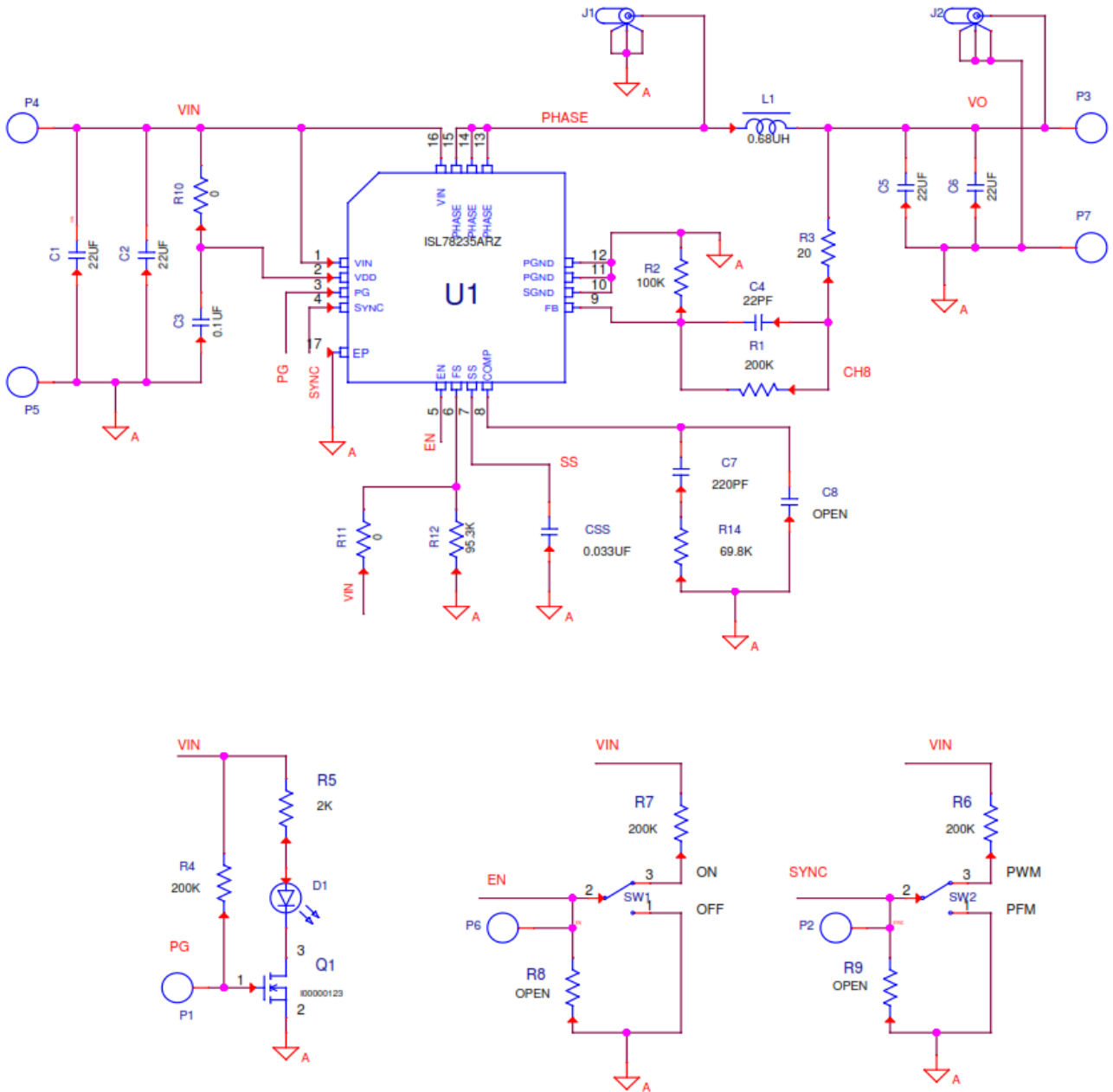

NOTES:

3. ISL78235EVAL1Z schematics shown.
4. ISL78233EVAL1Z and ISL78234EVAL1Z schematics are equivalent.

Bill Of Materials

PART NUMBER	QTY	UNITS	REFERENCE DESIGNATOR	DESCRIPTION	MANUFACTURER	MANUFACTURER PART
ISL78233EVAL1Z	1	ea.		PWB-PCB, ISL78235, REVA, RoHS	IMAGINEERING INC	ISL78233EVAL1Z
ISL78234EVAL1Z	1	ea.		PWB-PCB, ISL78234, REVA, RoHS	IMAGINEERING INC	ISL78234EVAL1Z
ISL78235EVAL1Z	1	ea.		PWB-PCB, ISL78235, REVA, RoHS	IMAGINEERING INC	ISL78235EVAL1Z
ISL78233ARZ or ISL78234ARZ or ISL78235ARZ	1	ea.	U1	IC- 3A, 4A, or 5A BUCK REGULATOR, 16P, QFN, 3x3, RoHS	INTERSIL	ISL78233ARZ or ISL78234ARZ or ISL78235ARZ
H1045-00220-50V5-T	1	ea.	C4	CAP, SMD, 0603, 22pF, 50V, 5%, COG, RoHS	VENKEL	C0603C0G500-220JNE
H1045-00221-50V10-T	1	ea.	C7	CAP, SMD, 0603, 220pF, 50V, 10%, X7R, RoHS	MURATA	GRM188R71H221KA01D
H1045-00333-16V10-T	1	ea.	CSS	CAP, SMD, 0603, 33000pF, 16V, 10%, X7R, RoHS	VENKEL	C0603X7R160-333KNE
H1045-00104-16V10-T	1	ea.	C3	CAP, SMD, 0603, 0.1μF, 16V, 10%, X7R, RoHS	VENKEL	C0603X7R160-104KNE
H1045-DNP	0	ea.	C8	CAP, SMD, 0603, DNP-PLACE HOLDER, RoHS		
H1065-00226-10V10-T	4	ea.	C1, C2, C5, C6	CAP, SMD, 1206, 22μF, 10, 10%, X7R, RoHS	TAIYO YUDEN MURATA	LMK316AB7226KL-TR GRM31CR71A226KE15L
IHLP2020CZERR68M01-T	1	ea.	L1	COIL-PWR INDUCTOR, SMD, 5.49x5.18, 0.68μH, 20%, 10.2A, RoHS	VISHAY	IHLP2020CZERR68M01
131-4353-00	2	ea.	J1, J2	CONN-SCOPE PROBE TEST PT, COMPACT, PCB MNT, RoHS	TEKTRONIX	131-4353-00
1514-2	4	ea.	P4, P5, P7, P8	CONN-TURRET, TERMINAL POST, TH, RoHS	KEYSTONE	1514-2
5002	3	ea.	P1, P2, P6	CONN-MINI TEST POINT, VERTICAL, WHITE, RoHS	KEYSTONE	5002
LTST-C170CKT	1	ea.	D1	LED-GaAs RED, SMD, 2x1.25mm, 100mW, 40mA, 10mcd, RoHS	LITEON/VISHAY	LTST-C170CKT
2N7002-7-F-T	1	ea.	Q1	TRANSISTOR, N-CHANNEL, 3 LD, SOT-23, 60V, 115mA, RoHS	DIODES, INC.	2N7002-7-F
H2511-00200-1/10W1-T	1	ea.	R3	RES, SMD, 0603, 20Ω, 1/10W, 1%, TF, RoHS	PANASONIC	ERJ-3EKF20R0V
H2511-00R00-1/10W-T	2	ea.	R10, R11	RES, SM, 0603, 0Ω, 1/10W, 5%, TF, RoHS	GENERIC	
H2511-01003-1/10W1-T	1	ea.	R2	RES, SMD, 0603, 100k, 1/10W, 1%, TF, RoHS	VENKEL	CR0603-10W-1003FT
H2511-02001-1/10W1-T	1	ea.	R5	RES, SMD, 0603, 2k, 1/10W, 1%, TF, RoHS	KOA	RK73H1JTTD2001F
H2511-02003-1/10W1-T	4	ea.	R1, R4, R6, R7	RES, SMD, 0603, 200k, 1/10W, 1%, TF, RoHS	VENKEL	CR0603-10W-2003FT
H2511-06982-1/10W1-T	1	ea.	R14	RES, SMD, 0603, 69.8k, 1/10W, 1%, TF, RoHS	VENKEL	CR0603-10W-6982FT
H2511-09532-1/10W1-T	1	ea.	R12	RES, SMD, 0603, 95.3k, 1/10W, 1%, TF, RoHS	VENKEL	CR0603-10W-9532FT
H2511-DNP	0	ea.	R8,R9	RES, SMD, 0603, DNP-PLACE HOLDER, RoHS		
GT11MSCBE-T	2	ea.	SW1, SW2	SWITCH-TOGGLE, SMD, 6 PIN, SPDT, 2POS, ON-ON, RoHS	ITT INDUSTRIES/ C&K DIVISION	GT11MSCBE

ISL78233EVAL1Z, ISL78234EVAL1Z, ISL78235EVAL1Z Board Layout

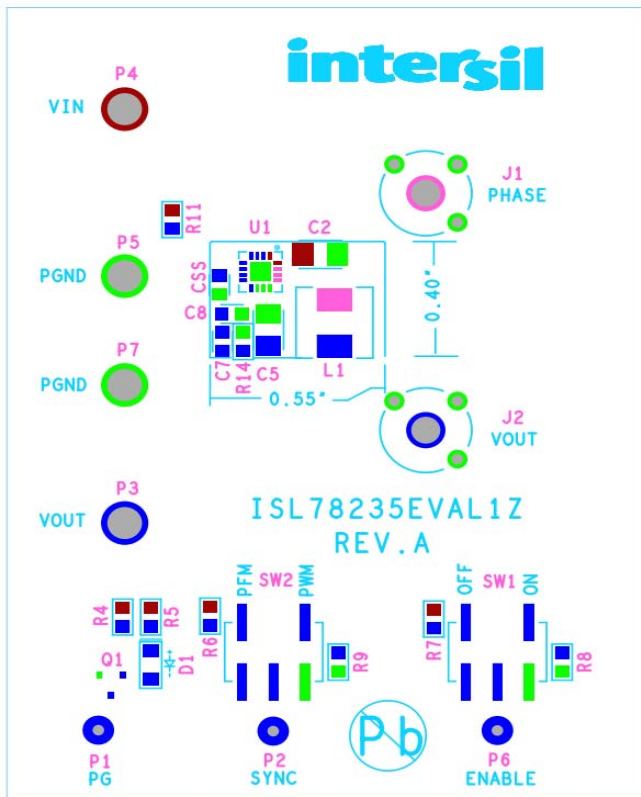

FIGURE 2. TOP LAYER SILKSCREEN

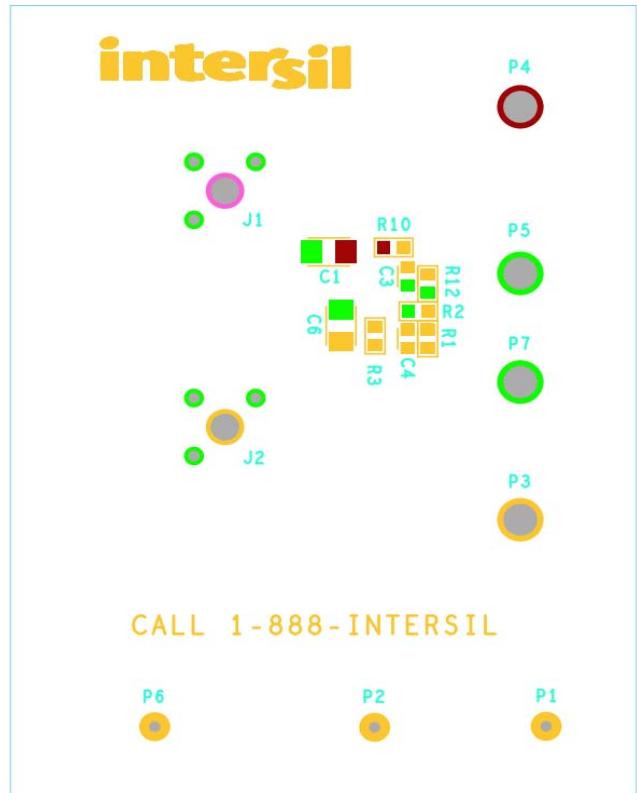

FIGURE 3. BOTTOM LAYER SILKSCREEN

NOTES:

- 5. ISL78233 board silkscreen name is ISL78233EVAL1Z
- 6. ISL78234 board silkscreen name is ISL78234EVAL1Z

ISL78233EVAL1Z, ISL78234EVAL1Z, ISL78235EVAL1Z Board Layout

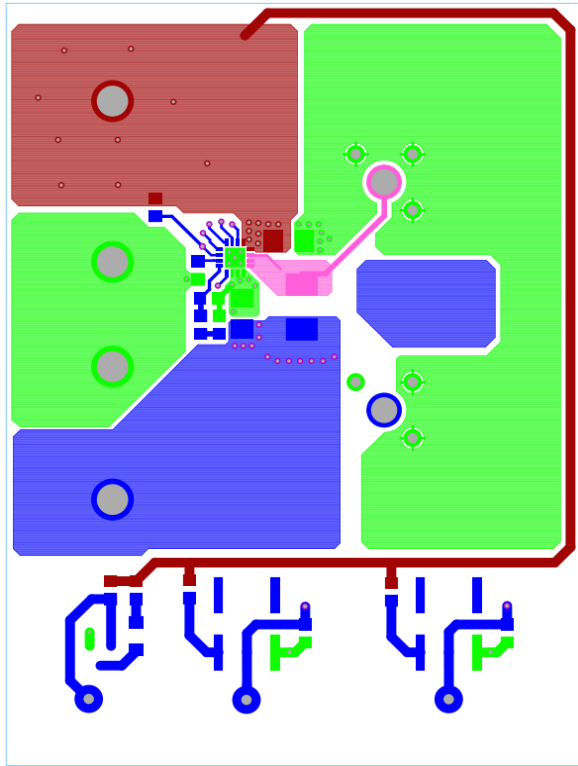

FIGURE 4. LAYER 1 PCB

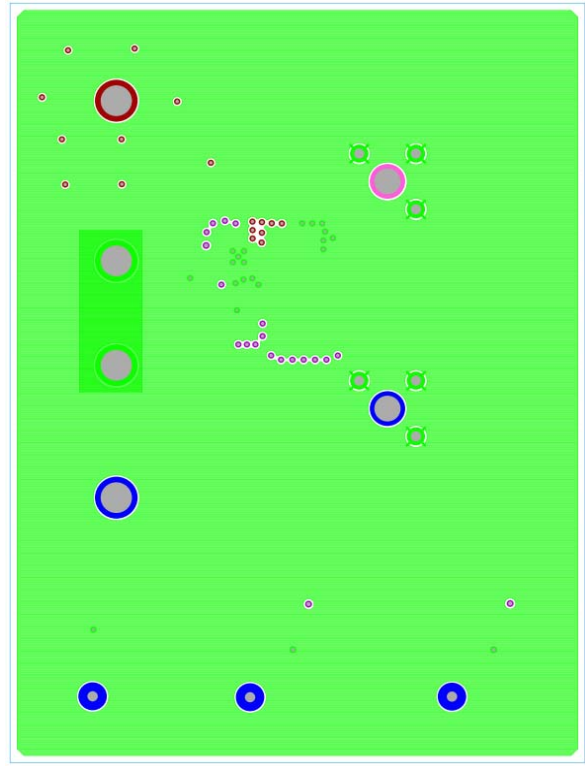

FIGURE 5. LAYER 2 PCB

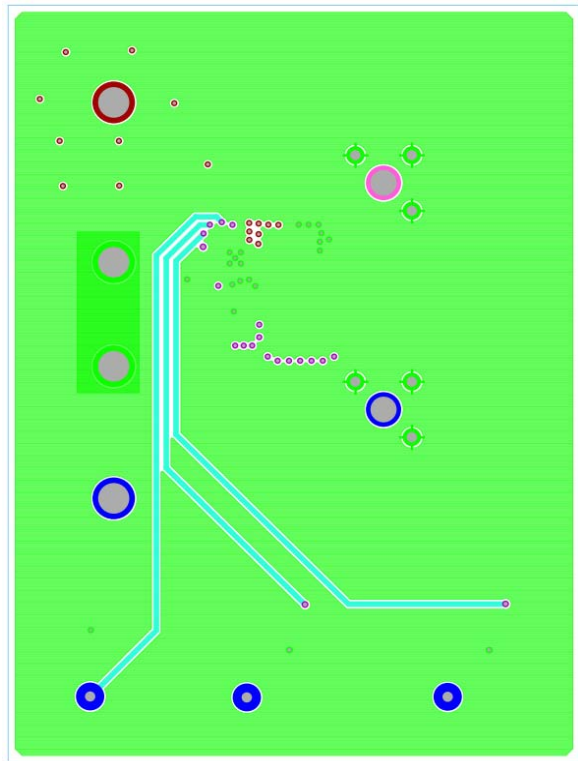

FIGURE 6. LAYER 3 PCB

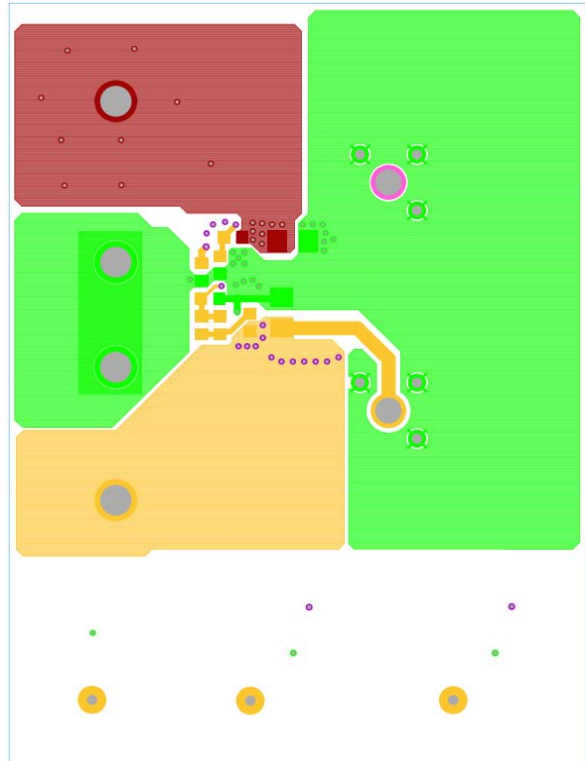

FIGURE 7. LAYER 4 PCB

Typical Performance Curves

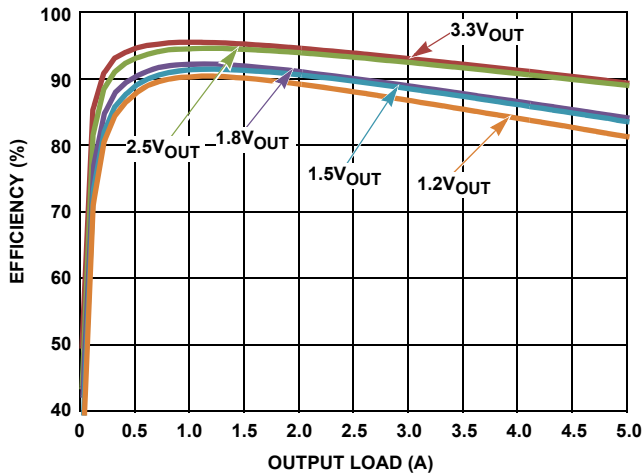

FIGURE 8. EFFICIENCY vs LOAD (5V_{IN}; SYNC = VDD)

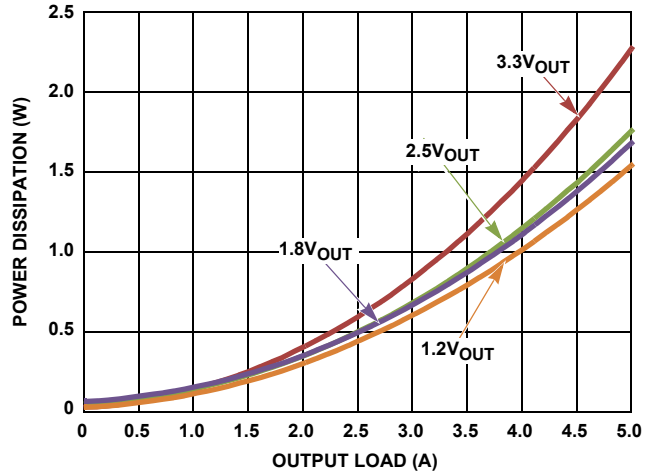

FIGURE 9. POWER DISSIPATION vs LOAD (5V_{IN}; SYNC = VDD)

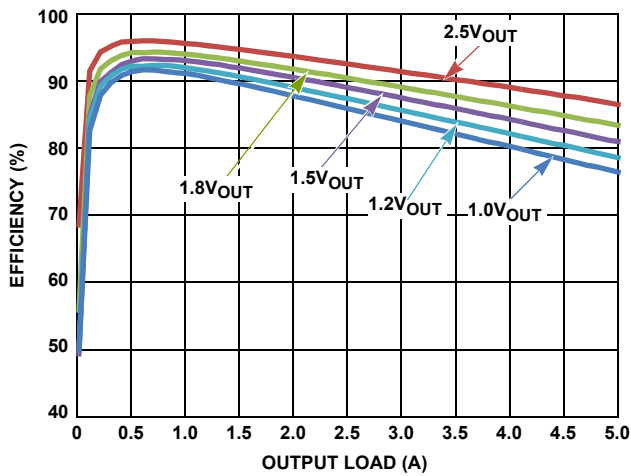

FIGURE 10. EFFICIENCY vs LOAD (3V_{IN}; SYNC = VDD)

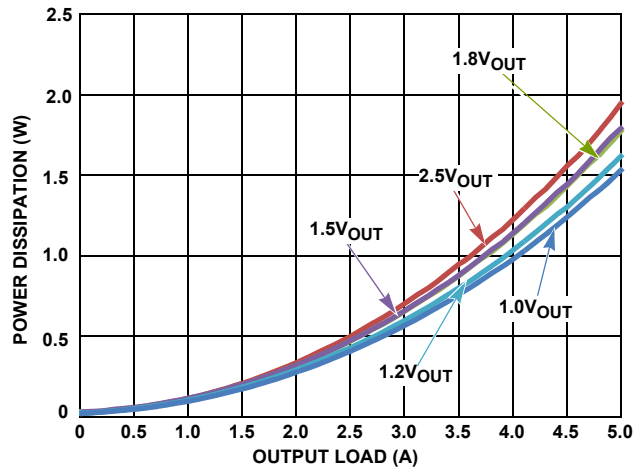

FIGURE 11. POWER DISSIPATION vs LOAD (3V_{IN}; SYNC = VDD)

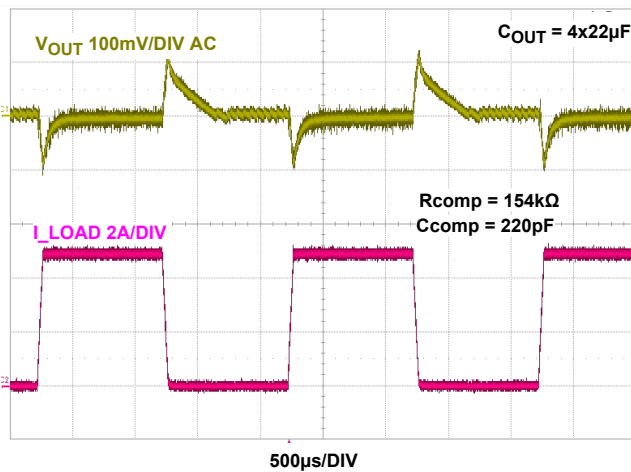

FIGURE 12. LOAD TRANSIENT 0A TO 5A; 0.5A/μs (SYNC = GND)

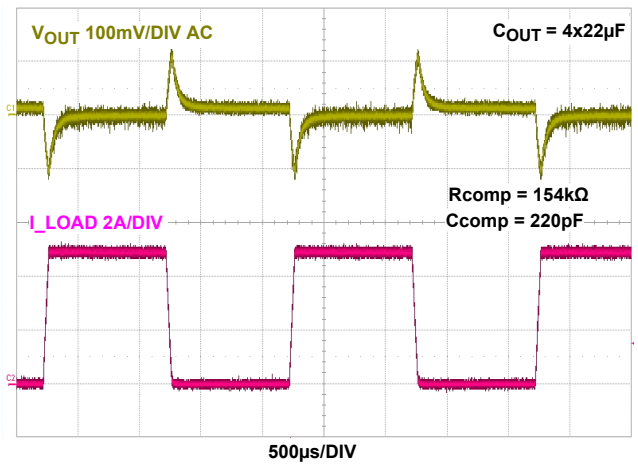

FIGURE 13. LOAD TRANSIENT 0A TO 5A; 0.5A/μs (SYNC = VDD)

Intersil Corporation reserves the right to make changes in circuit design, software and/or specifications at any time without notice. Accordingly, the reader is cautioned to verify that the document is current before proceeding.

For information regarding Intersil Corporation and its products, see www.intersil.com